

English

 **SCHICK**
Dentalgeräte

Georg Schick Dental GmbH
Lehenkreuz 12
D-88433 Schemmerhofen
Telefon 07356/9500-0
Telefax 07356/9500-95
E-Mail info@schick-dental.de
Internet www.schick-dental.de

Operating Instructions C3-Master



We are pleased that you decided to buy a highly developed piece of equipment from SCHICK and would like to wish you every success when working with your new C3 Master motor unit.

We wrote these operating instructions to enable you to get accustomed to your new piece of equipment and to provide you with the correct operating and maintenance instructions.

Index

1. Safety information
Caution!
2. Range of applications
3. Summary C3-Master units
4. List of contents - accessoires
5. Setting up / operating the unit
6. Cruising System / digital display
7. Exchanging the rotary instruments
8. Replacing the chuck
9. Maintenance and care
10. Possible faults
11. Technical Data
12. Declaration of conformity

1. Safety information

- 1.1 Ascertain that your mains supply coincides with the data on the rating plate.
- 1.2 C3-Master - units are not suitable for the following applications:
 - in areas where there is a risk of explosion
 - for medical applications
 - for working on moist materials
- 1.3 Ensure that all regulatory requirements are observed during use
 - always wear protective glasses
 - provide enough light at the working place
 - use dust suction
- 1.4 Under no circumstances should the motor handpiece be cleaned with compressed air.
- 1.5 Before putting the handpiece down, always insert a rotary instrument or the pin, supplied with the unit, into chuck.

Caution:

- When using rotary instruments, do not exceed the maximum speeds laid down by their manufacturer.
- When operation with left-hand rotation, the collet may loosen when there is a high load.
- Repairs and other technical procedures must only be carried out by suitable qualified personnel, authorized by SCHICK.
- SCHICK do not guarantee the C3 Master unit should it not have been used in accordance with the operating instructions.

2. Range of applications

The C3 Master unit is designed for universal use in dental laboratories when trimming crowns and bridges, respectively acrylic and light chrome cobalt dentures.

With its speed range from 1.000 - 50.000 rpm the SCHICK C3 Master - unit allows to work all dental materials.

The motorhandpiece is ergonomical, small shaped and runs smoothly, thus eliminating user-fatigue and making it economical to use over long periods. The progressive processor controller constantly monitors the unit for overloading. A second thermal fuse, which is independent of the computer, provides further protection. Thus the C1 Master - unit offers a maximum of safety.

Conditions of environment:

- interior 5° - 40° C.
- up to 2,000 meter over sea level

Categorie of overvoltage: II

Grade of pollution: 2



3. Summary C3-Master units

C3/SK complete
article no. 7005



C3/SF complete
article no. 7010



C3/ST complete
article no. 7015



Accessories:

digital indicator
article no. 6380



NH / DNH
riveting hammer 1
article no. 1850
twin riveting hammer 2
article no. 1860









—1

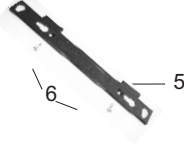

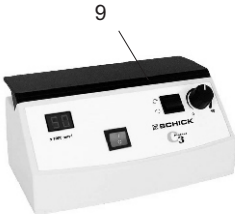
—2

4. List of contents - accessories/spare parts

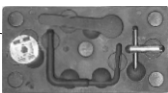
C3/SK	complete	article-no.	7005		
C3/SK	knee controller 1	7035			
C3/MH	motorhandpiece and cable 2	7050			
	handpiece rack - with two keys for changing chuck 3	6385			
	mains cable 4	2160			
	suspension strip 5	5614			
	screws - 2 pieces - 6	3170			
C3/SK-D	with digital indicator complete	7005/1			
C3/SK-D	knee controller with attachment for digital indicator 1	7035/1			
C3/MH	motorhandpiece and cable 2	7050			
	handpiece rack - with two keys for changing chuck 3	6385			
	mains cable 4	2160			
	suspension strip 5	5614			
	screws - 2 pieces - 6	3170			
	digital indicator 7	6380			
C3/SF	complete	article-no.	7010		
C3/SF	foot controller 8	7040			
C3/MH	motorhandpiece and cable 2	7050			
	handpiece rack - with two keys for changing the chuck 3	6385			
	mains cable 4	2160			
C3/SF-D	with digital indicator complete	7010/1			
C3/SF-D	foot controller with attachment for digital indicator 8	7040/1			
C3/MH	motorhandpiece and cable 2	7050			
	handpiece rack - with two keys for changing the chuck 3	6385			
	mains cable 4	2160			
	digital indicator 7	6380			
C3/ST	complete	article-no.	7015		
C3/ST	control unit table top model 9	7045			
C3/MH	motorhandpiece and cable 2	7050			
	dynamic foot-switch 10	6371			
	handpiece rack - with two keys for changing the chuck 3	6385			
	mains cable 4	2160			
spare parts					
	Chucks:				
	Standard: Ø 2,35mm	6642			
	Optional: Ø 3,00mm	6643			
	chuck key	5160/1			
	counter stay wrench	6223			
	motor cable complete	7250			

5. Setting up

Operating the different versions

Cruising system and operating with digital indicator
see discription on page 6

all versions

- 5.1 Ascertain, that your mains supply coincides with the data on the rating system.
- 5.2 Plug the mains cable 9 into the unit 1 and into a mains socket.
- 5.3 Plug the motor cable 3 into the socket 2 on the rear of the unit (quarter-turn catch).
- 5.4 Place the handpiece on the rest 8 supplied with it.

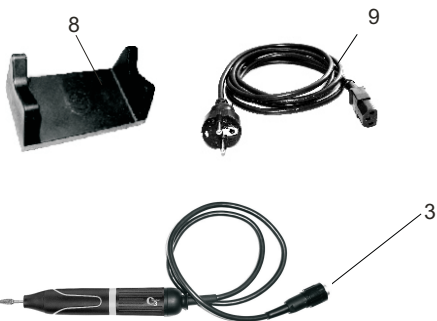

knee controller version only

- 5.5 Press the mains switch 4 on the front of the unit. The control lamp will come on. The unit is switch off by pressing the mains switch 4 again.
- 5.6 Set the speed controller 5 to the desired speed. The set speed can be reached right away by pressing the knee controller 6. The speed controller is provided with a mechanic locking which only allows speeds up to 40.000 rpm unless the segment 5 is operated deliberately. To reach speeds > 40.000 rpm press segment 5 whilst turning speed controller.

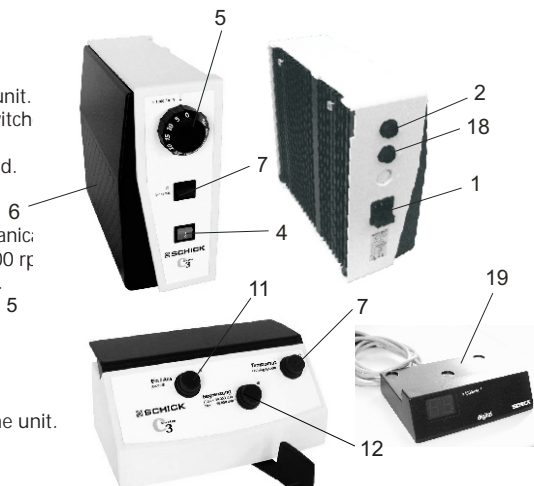

foot controller version only.

- 5.5 Press the mains switch 11 on the front of the unit. The LED will flash up. The unit is switched off by pressing the mains switch 11 again.
- 5.6 The speed can be varied progressively between 1.000 - 50.000 rpm by moving the foot pedal 13. For your safety the unit is provided with a mechanical speed limitation 12. If the red warning light lights up, up to 50.000 rpm have been enabled. If the red warning light at the limiting switch is not lit up, the RPM's are limited to a maximum of 30.000.

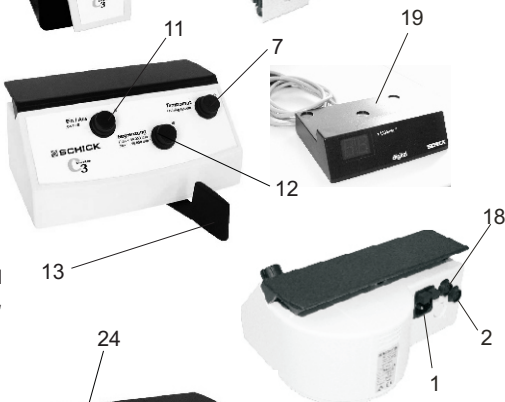

bench controller version only

- 5.5 Plug the dynamic foot-switch 21 into the socket 23 on the rear of the unit (quarter-turn-catch).
- 5.6 Switch on the mains switch 20 on the front of the unit (the control lamp lights up). The unit is switched off by pressing the mains switch 20 again.
- 5.7 Set the speed control knob 22 to the desired speed. (see digital display 24) The motor can be switched on or off by moving the pedal and the speed can be varied progressively up to the set speed.
- 5.8 The bench unit can also be operated without the dynamic foot-switch. Set the speed control knob 22 to the desired speed. The motor will begin to run immediately.

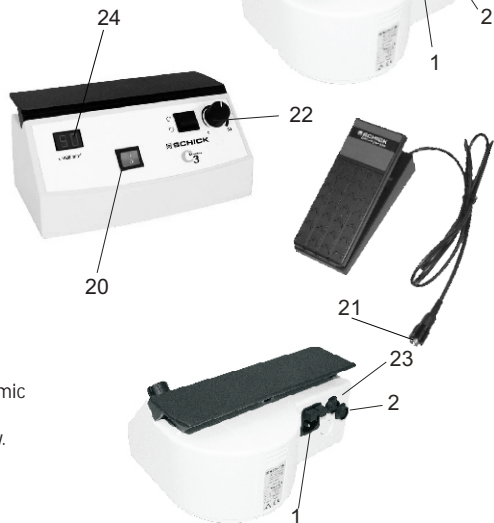

6. Function of Cruising Speed Control - Tempomat

Your C3 Master knee/foot-controller is equipped with a cruising speed control -Tempomat-. This extended control system enables the operator to select and store a given speed. A considerable facility for maintaining a constant speed f. e. for work underneath the microscope or for extensive work.

Cruising speed control 7 switched 'on'

- yellow LED is shining
- each speed which is kept more than 1 sec. is stored
- without pressing the knee/foot controller the motor is running with the speed stored
- by operating the knee/foot controller again or by pressing the switch 7 the stored speed is canceled
- to select a new speed please operate the knee/foot control again until the desired speed is reached and keep the control for about 1 sec. at this speed; the new speed then is stored.

A stored speed can be canceled by switching off the cruising speed control (yellow LED not shining).

7. Exchanging the rotary instruments

The chuck is opened, respectively, closed by turning the outer sleeve 13 of the handpiece.

Caution:

Only ever exchange the rotary instrument with the motor switched off!
With regard to the precision and service-life of the chuck, an instrument must always be inserted into it - even when the handpiece is not in use.

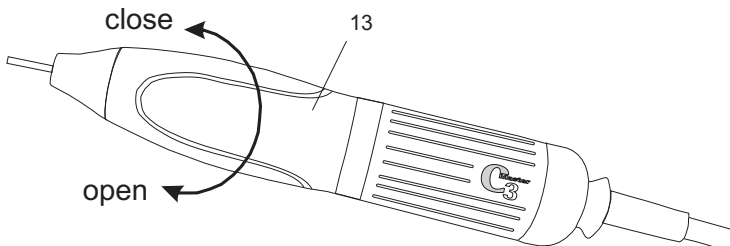

Operating the unit with a digital display

knee and foot models only

Insert the plug on the digital display 19 into the socket 18 in the rear of the unit.

When the unit is switched on, the digital speed indicator shows the pre-selected maximum speed. Once the motor is running, the actual speed of the motor is displayed.

To save space, the digital speed indicator can be placed under the handpiece rack or, if required, adhered to a bench top with double-sided adhesive tape.

table top unit

into the table top unit a digital display is integrated - the display operates in the same way as described above.

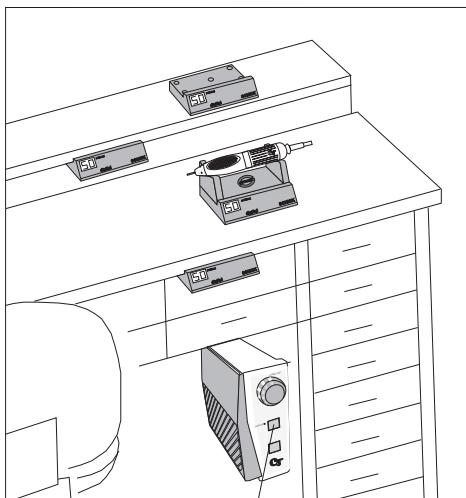

7

8. Replacing the chuck

- 8.1 Remove the motor cable 15. To do so unscrew the cap 16 from the motor and loosen the cable by pulling out the plug-in seal 17.
- 8.2 Open the chuck and withdraw the rotary instrument. Unscrew the end of the handpiece 21 (right-handed thread).
- 8.3 Remove sealing cap 24
- 8.4 Use a number 6223 wrench 23 to hold the motor end of the spindle. Engage the triangular section of the chuck with a No. 5160/1 chuck tool 22. To prevent the chuck becoming distorted, an instrument shank or the pin supplied must always be inserted into it. Hold the number 6223 23 wrench tightly and turn the chuck tool anti-clockwise to unscrew the chuck completely - the chuck has a right-handed thread!

- 8.5 Clean the chuck, grease it lightly and place it in the spindle. Use the tools to screw the chuck in - clockwise and as far as possible - as described in section 8.4, and **tighten it slightly**. Replace the plug-in seal 17 and screw the cap 16 back into place. Screw the sealing cap 24 and the end of the handpiece 21 on again.

Please note:

The tools 22 and 23 are to be found in the base of the handpiece rest!

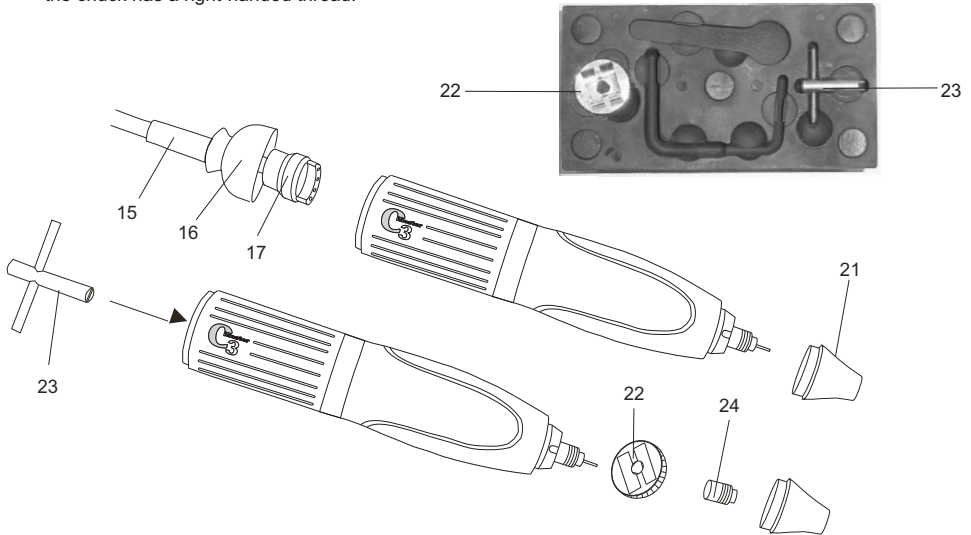

9. Care and maintenance

Caution: Do not clean your C3 Master motorhandpiece with compressed air!

Chuck: should be cleaned and re-greased once in a while, depending on how dirty it is.

As C3 Master units have no commutators, carbon brushes or ventilation parts, no further maintenance is required.

10. Possible faults

Should the handpiece be overloaded, respectively, jammed, for safety reasons the unit will switch itself off.

- Release knee/foot switch and operate it again; the unit is ready for use immediately
bench controller version only

- When using the bench version without a pedal switch, the speed control knob should be turned to "0", when the desired speed is selected again; the unit is ready for use immediately.

- When using the bench version with a pedal switch it should be released and operated again; the unit is then ready for use again.

all versions

if the unit should not be running after doing as described above the 2 fuses have to be checked and eventually exchanged. The fuses (2 x 2A inert) are to be found at the rear of the unit beneath the socket 1.

11. Technical Data

Dimensions:	Width	C3/SK 107mm	C3/SF 225mm	C3/ST 225mm
	Height	243mm	110mm	110mm
	Dept	253mm	170mm	170mm
Weight		3,7 kg	3,0 kg	2,9 kg
C3/MH	Length	158mm	Weight	240g
Power Supply:	AC 220-240V	115V	100V	
Nominal frequency:	50/60Hz			
Power input:	270W			
Type:	C3 Master			
Speed range:	1.000 - 50.000 min rpm			
Torque max.:	7,8 Ncm			
Safety class:	I			

This unit complies with the current VDE (German association of electrical technicians) regulations concerning safety and suppression.

These operating instructions should be readily accessible and are best kept close to the unit itself.

We would like to take this opportunity to advise you that a proper repair service and suitable qualified personnel are required for such highly developed technical equipment.

SCHICK guarantees to carry out perfect repairs using original spare parts.

12. Declaration of Conformity



We, GEORG SCHICK DENTAL GmbH
Lehenkreuz 12
88433 Schemmerhofen
declare herewith, that the product

C3 Master installations consisting of
C3 Motorhandpiece 7050 connected with
C3 Control unit 7035, 7040 and 7045

is in conformity with the following provisions of Directive:

92/59/EWG (allgemeine Produktsicherheit)
98/37/EG (Maschinenrichtlinie)
2006/95/EG (Niederspannungsrichtlinie)
89/336/EWG (EMV-Richtlinie)

According to following standards:

EN 61010-1 (Sicherheitsbestimmungen für
elektr. Mess-, Regel- und Steuergeräte)
EN 55014 (Funkentstörung)
EN 55104 Teil 1 (Störfestigkeit)
EN 1050:1996 (Sicherheit von Maschinen)
EN ISO 12100-1 (Sicherheit von Maschinen)
EN ISO 12100-2 (Sicherheit von Maschinen)

Schemmerhofen, December 2005

W. Schick
managing director

manufacturer:



SCHICK
Dentalgeräte

Georg Schick Dental GmbH
Lehenkreuz 12
D-88433 Schemmerhofen
Telefon 07356/9500-0
Telefax 07356/9500-95

Internet: <http://www.schick-dental.de>
E-mail: info@schick-dental.de